

3520 Sugarcane Harvester (120701 -)



JOHN DEERE

PARTS CATALOG

3520 Sugarcane Harvester (120701 -)

PC11504 (Apr-13) English

John Deere Thibodaux

North America Edition
Printed in U.S.A. (Revised)
COPYRIGHT © 2013
DEERE & COMPANY
Moline, Illinois
All rights reserved



Introduction and Product Information

CM083520001 A.1

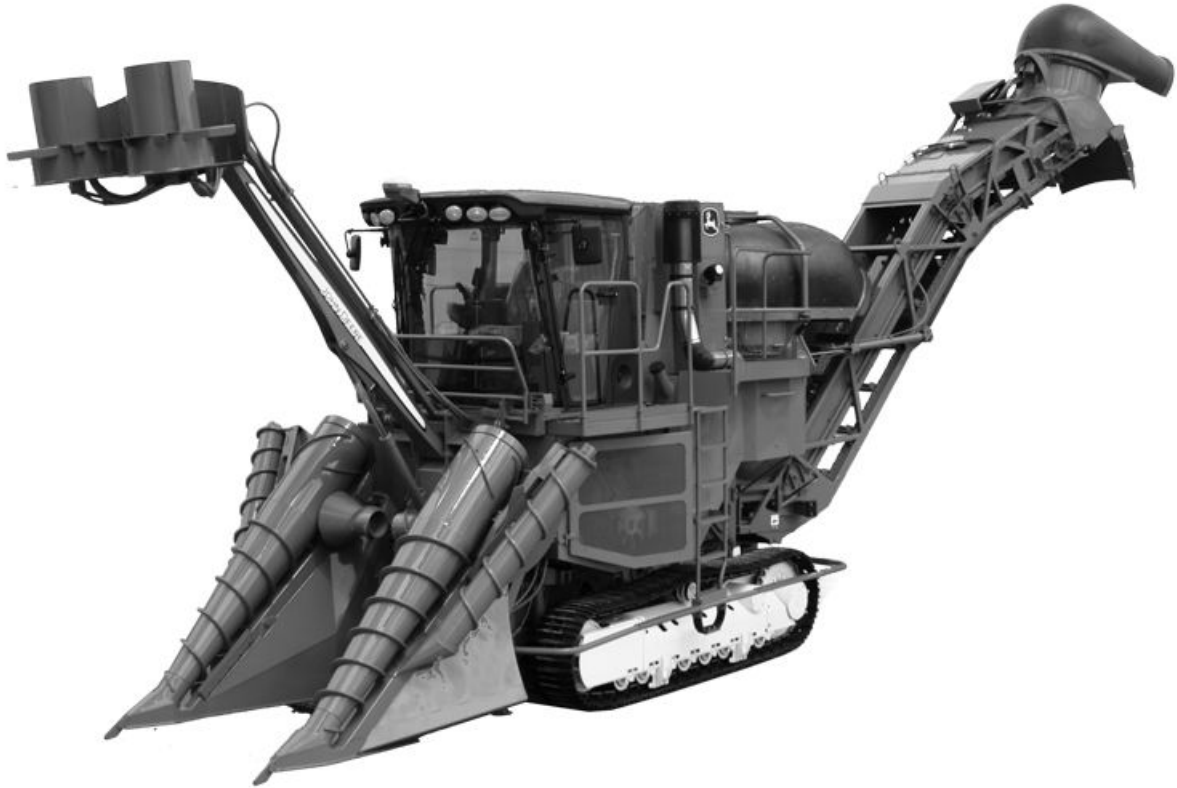

John Deere 3520 Sugar Cane Harvester

(Specifications and design subject to change without notice)

Short Block Serial Number (Stamped Into Block)

RGP4854 A.1

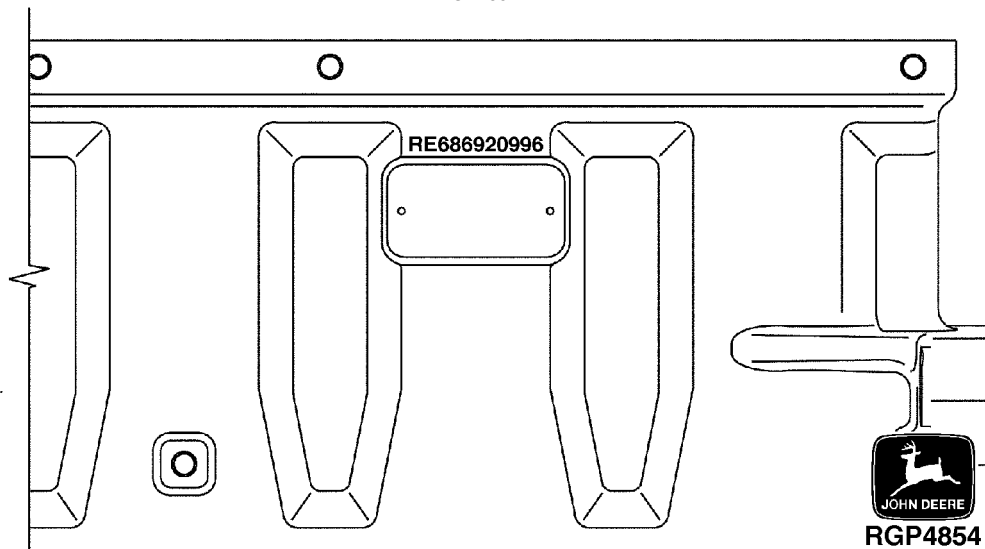

New short blocks include 2-37H44 drive screws. Remove old engine serial number plate from block and attach to new block, using these screws, to reference external parts.

Explanation of stamped number:

1. DESIGNATES SERVICE PART NUMBER	RE68692
2. DESIGNATES MONTH ASSEMBLED	09
3. DESIGNATES YEAR ASSEMBLED	01

Engine Serial Number Plate — 6081 & 6090

RGP11387 A.1



RGP11387

Engine Serial Number is Defined by 13 Characters	
First Line	Designates
1 — Two letters for engine factory designation	RG: Waterloo, USA, JX: Rosario, Argentina
2 — One digit for number of cylinders.	6 Cylinder
3 — Three digits for displacement in liters	081: 8.1 Liter, 090: 9.0 Liter
4 — One letter for emission level	B= Non-Certified C= Tier1/Stage I emission level G= Tier 2/Stage II emission level L= Tier 3/Stage IIIA emission level R= Interim Tier 4/Stage IIIB emission level
5 — Six digits	123456= Engine build sequence number. Sequence numbers start at 000001
Engine Type is Defined by 9 Alpha-Numerical Characters	
6 — Four digits	Same as items 2 and 3 above
7 — One letter for aspiration type	A= Turbocharged with air-to-water after-cooler D= Naturally Aspirated T= Turbocharged H= Turbocharged with air-to-air after cooler S= Turbocharged with air-to-sea water after-cooler
8 — One or two letters for OEM application	F: OEM, FM: Marine, FH: HazLoc, FN: Compressed Natural Gas
8 — One or two letters for John Deere Vehicle application	TJ: Forestry, RW: Tractor, H, Z, CQ: Combine, N: Picker/Sprayer, DW: Construction, T8: Sugar Cane Harvester
9 — Two or three digits for version	485

**Thanks very much for your reading,
Want to get more information,
Please click here, Then get the complete
manual**

JustClickHere 

NOTE:

**If there is no response to click on the link above,
please download the PDF document first, and then
click on it.**

**Have any questions please write to me:
admin@servicemanualperfect.com**

Engine Serial Number Plate — 6081 & 6090

RGP11387 A.1



RGP11387

Engine Serial Number is Defined by 13 Characters	
First Line	Designates
1 — Two letters for engine factory designation	RG: Waterloo, USA, JX: Rosario, Argentina
2 — One digit for number of cylinders.	6 Cylinder
3 — Three digits for displacement in liters	081: 8.1 Liter, 090: 9.0 Liter
4 — One letter for emission level	B= Non-Certified C= Tier1/Stage I emission level G= Tier 2/Stage II emission level L= Tier 3/Stage IIIA emission level R= Interim Tier 4/Stage IIIB emission level
5 — Six digits	123456= Engine build sequence number. Sequence numbers start at 000001
Engine Type is Defined by 9 Alpha-Numerical Characters	
6 — Four digits	Same as items 2 and 3 above
7 — One letter for aspiration type	A= Turbocharged with air-to-water after-cooler D= Naturally Aspirated T= Turbocharged H= Turbocharged with air-to-air after cooler S= Turbocharged with air-to-sea water after-cooler
8 — One or two letters for OEM application	F: OEM, FM: Marine, FH: HazLoc, FN: Compressed Natural Gas
8 — One or two letters for John Deere Vehicle application	TJ: Forestry, RW: Tractor, H, Z, CQ: Combine, N: Picker/Sprayer, DW: Construction, T8: Sugar Cane Harvester
9 — Two or three digits for version	485

Serial Numbers

The combine serial number is located on right-hand side of Operator's platform.

The engine serial number is located on the fuel injection pump side of the engine block.

The engine transmission serial number is located on the rear of the transmission case.

The wheel motor serial number (with four-wheel drive) is located on top of motor.

The straw chopper serial number plate is located on the right-hand side of the straw chopper.

The hydrostatic pump serial number is located on the side of the pump.

The transmission serial number is located on the right-hand side of the transmission the hydrostatic motor serial number is located on top of the motor.

To The Customer

The part numbers in this Parts Catalog were correct at the time of publication. Per John Deere policy, we continuously improve our products. Therefore, when ordering parts verify the part numbers with your dealer.

SI Units of Measure

Metric dimensions are provided as applicable throughout this parts catalog.

Bolt and Cap Screw Strength Identification

Bolts and cap screws required to have high-strength qualities equivalent to metric property class 10.9 (SAE grade 8) or higher are identified throughout this catalog by the description 10.9, 12.9 or 14.9. All standard bolts and cap screws are metric property class 8.8 (SAE grade 5) or lower.

Serial Number Listing Information

Serial number information is listed to show on which machines each part can be used; for example:

- **The part can be used on all products.**
- 000000** - **The part can be used on products beginning with the serial number listed.**
- **000000** **The part can be used on products up to and including the serial number listed.**
- 000000** - **000000** **The part can be used on products between and including the serial number listed.**

When XXXXXX's are listed in place of a serial number, a serial number change was made, but the exact serial number was not available at the time of publication.

Illustrations

Illustrations in this catalog are only intended as a reference for dealers and customers. These illustrations do not necessarily represent the exact view of the parts.

Box-Enclosed Illustrations

Box-enclosed keyed parts in the illustration are available as a service assembly or an attachment. These parts may also include parts not available for service. The illustrations may not show all individual parts of an attachment. A box not keyed includes non-current parts.

Orientation Of Product

An arrow shown with an illustration is to indicate the direction of product forward travel. Right Hand (RH) and Left Hand (LH) sides are determined by product forward travel.

Orientation of Engine

Right Hand (RH) and Left Hand (LH) sides are determined by standing at flywheel and facing the engine.

John Deere Remanufactured Components

The REMAN parts listed in this catalog are intended for the repair or replacement of failed or worn original equipment components. John Deere Reman components are manufactured to stringent John Deere standards and produced to original John Deere specifications that incorporates the latest design and performance improvement updates.

Ag and Turf Crop Harvester — Trademarks

AutoQuad™	JDLink™	INFOTRAK™
AutoTrac™	John Deere™	DieselScan™
Bullet Rotor™	Load Command™	John Deere Break-In™
GreenStar™	Service ADVISOR™	Break-In™
Harvest Smart™	Spout-Trak™	Torq-Gard Supreme™
HarvestLab™	StarFire™	COOL-GARD™
HARVESTRAK™	STS™	CoolScan PLUS™
HillMaster™	SyncroPlus™	Harvest Monitor™
HydraFlex™	SyncShift™	GreenStar 2 System™
PowrReverser™	SyncShuttle™	IntelliGuard™
PowrSync™	SyncReverser™	DURA-MAX™
ProDrive™	TLS™ (Triple-Link Suspension)	Torq-Gard Supreme™
Roll-Gard™	Field Office™	Quik-Tatch™
ClimaTrak™	MIG™	Posi-Torq™
ComfortGard™	Nothing Runs Like a Deere™	Contour-Master™
CommandARM™	PowerGard™	DIAL-A-MATIC™
CommandCenter™	PowerTech™	DIAL-A-SPEED™
CommandTouch™	PowrQuad™	Funk™
Contour-Master™	IronGard™	iTorque™
CTS™	Oilscan™	Phoenix™
CoolScan™	PowerTech™	IVLOC™
Plus-50™	TMII™	IVT™
PowerTech Plus™	TMIII™	

Ag and Turf Crop Harvester — Terms and Abbreviations

Phrase	Meaning	Phrase	Meaning
A/C	Air Conditioning	L	Number of Links to Chains
ALSO ORDER	Also Order	NLA	No Longer Available
APPL	This Application Only	NSEP	Not Supplied Separately
AR	As Required	OD	Outside Diameter
ASSY	Complete Assembly	OPTION	Option
BCU	Basic Control Unit	OPTIONAL	Optional
CNLA	Complete No Longer Available (Order Individual Parts)	OR	Or
CTL	Cut To Length	ORD	Order
ECU	Engine Control Unit	ORD W/	Order With
ETC	Electronic Temperature Control	OS	Oversize
FI	Field Installation Kit	PKG	Package of
FIP	Fuel Injection Pump	RATIO	Ratio
FOR	For	RCU	Reverser Control Unit
FRONT	Front	REAR	Rear
GSD	GreenStar™ Display	REMAN	Remanufactured
HTC	Heater Control Unit	RH	Right Hand
ID	Inside Diameter	STD	Standard
INCL	Includes	SUB	Replaced by
INCL KEYS	Including Keys	SUB FOR	Substitute for
JDL	JDLink™ Control Unit	TK	Thickness
KIT	Kit	UIC	User Interface Control Unit
LGTH	Length	UIM	User Interface Module
LH	Left Hand	UP	Upper
LOW	Lower	USE WITH	Use With
MARKED	Marked	W/	With
MF	Made From	W/O	Without
NA	Not Applicable	Z	Gear and Sprocket Teeth Number

Table of Contents

20 Engine 6090HT804.....	26
22 Engine 6090HT803.....	93
025 Engine Attachment 3520.....	166
030 Fuel / Air 3520.....	178
040 Electrical 3520.....	194
050 Power Train (Hydrostatic)-Track 3520.....	302
052 Power Train, Hydrostatic (Wheel).....	332
055 Track 3520.....	358
057 wheel 3520.....	394
060 Steering and Brakes 3520.....	400
070 Hydraulics 3520.....	426
080 Body and Shields 3520.....	506
090 Operator Station 3520.....	606
100 Topper 3520.....	672
105 Crop Divider 3520.....	712
110 Base Cutter 3520.....	856
115 Feed Roller 3520.....	874
120 Chopper and Sill 3520.....	924
125 Primary Extractor 3520.....	978
130 Elevator and Secondary Extractor 3520.....	1006

Alphabetical Index

	Page		Page
1102 Rocker Arm Cover	26, 96	Air Conditioner and Heating Components, Cab	668
1303 Crankshaft Pulley and Damper.....	28, 98	Air Conditioner Pump and Lines	644
1405 Flywheel Housing	100	Air Conditioner Pump, Lines.....	644
1405 Flywheel Housing / Crankshaft Rear Oil Seal	29	Air Conditioning and Heating Ducts.....	666
1505 Flywheel	30, 102	Air Conditioning Compressor-7436-6090HT803	152
16 Inch Bent Shoes Sealed Chain.....	384	Air Conditioning Compressor-7436-6090HT804	78
1601 Fuel Injection Pump.....	32, 104	Air Conditioning Wiring Harness.....	290
1701 Air Intake Manifold.....	106	Air Duct, RH.....	666
1707 Intake Manifold.....	34	Air Filter, Recirculation.....	664
18 Inch Bent Shoes, Sealed Chain.....	376	Air Filters, Cab.....	664
18 Inch Straight Shoes with Sealed Chain, Track	388	Air Inlet, Turbo-5401-6090HT803.....	143
19 Pin Cab Harness	296	Air Intake-1707-6090HT804	34
1901 Oil Pan	36, 108	Air Intake-4392-6090HT803	128
20 Inch Bent Shoes, Sealed Chain.....	374	Air Intake-4392-6090HT804	56
20 Inch Bent Shoes, Standard Chain, Track	386	Air Pressure Sensor-1701-6090HT803	106
2001 Water Pump.....	38, 110	Air Temperature Sensor-1701-6090HT803	106
2107 Thermostat Cover.....	39, 111	Air Temperature Sensor-4392-6090HT803	128
22 Inches Disc, Basecutter GP.....	868	Air Temperature Sensor-4392-6090HT804	56
2201 Thermostat	40, 112	Alternator Mounting-6218-6090HT803	148
2321 Fan Drive.....	41, 113	Alternator Mounting-6218-6090HT804	74
24 Inch, Gearbox, Basecutter GP.....	858	Alternator With Wiring Harness-3121-6090HT803	121
24 Inches, Elevator Extension, Attachment.....	1062	Alternator With Wiring Harness-3121-6090HT804	49
24 Inches, Elevator Extension, Lines GP	1026	Am/Fm Radio GP (Option).....	616
24 Inches, Extension, Elevator, Attachment.....	1066	Armrest Harness and Switches, Track (- 121024).....	270
2407 Fan Belt	42, 114	Armrest Harness and Switches, Track (121210 -)	272
2699 Engine Coolant Heater - Plug.....	43, 115	Armrest Harness and Switches, Wheel (- 121024)	274
2802 Exhaust Manifold	116	Armrest Harness and Switches, Wheel (121210 -)	276
2814 Exhaust Manifold	44	Assembly Steering Column	402
2902 Ventilating System.....	46, 118	Assisted Basecutter Control Wiring Harness	208
30 Micron Fuel Filter and Lines	188	Attachment, ABC	438
3002 Starting Motor.....	48, 120	Attachment, Basecutter Leg, Breakaway Kit	860
3121 Alternator	49, 121	Attachment, CD KD, Rollers, Crop Divider	776
3510 Fuel Filter.....	50, 122	Attachment, Chopper Kit	946
3902 Thermostat Housing	52, 124	Attachment, Crop Divider Hydraulic Tilt.....	748, 754
4 Bar Roller GP, Feed Lower.....	880	Attachment, Elevator Extension	1016
4028 Oil Dipstick Tube	54, 126	Attachment, Elevator Extension, 12 Inches	1056
4392 Air Intake.....	56, 128	Attachment, Elevator Extension, 24 Inches	1064
4601 Cylinder Block.....	57, 129	Attachment, Elevator Extension, 34 Inches	1068, 1070
4609 Cylinder Block / Liners.....	58, 130	Attachment, Kit Elevator Extension	1014
4701 Crankshaft / Bearings.....	60, 132	Attachment, Outer Scroll and Side Knife LH	802
4801 Connecting Rods and Pistons	62, 134	Attachment, Outer Scrolls, Left.....	770
4901 Rocker Arm / Rocker Arm Shaft / Push Rod	64, 136	Attachment, Outer Scrolls, Right.....	764
5001 Engine Oil Pump (- 004976).....	66, 138	Attachment, Pump Hydraulic Tank Modifying Fittings	428
5003 Oil Pump (004977 -)	67, 139	Attachment, Reversing Fan	570
5101 Cylinder Head / Valves	68, 140	Attachment, Rotary Hand Pump.....	502
5299 Cylinder Block Fittings.....	70, 142	Attachment, Sill Roller, Chopper.....	926
5401 Turbo Air Inlet	143	Auto Track Display, Harness	296
5701 Water Pump Inlet.....	144	Autotrac Pedal Control GP (Option 7310,7320) (Track).....	610
5708 Water Pump Inlet.....	71	Autotrac™ Pedals	610
5901 Engine Oil Cooler / Oil Filter	146	Auxiliary Tilt Function Valve.....	750
5926 Engine Oil Cooler / Oil Filter	72	Auxiliary Tilt Function Valve, 4 Bank.....	498
6-Bank to 4-Bank Hydraulic Lines	752	Auxiliary Tilt Function Valve, Four Bank	750
6218 Belt Tensioner.....	74, 148	Axle Wide, Frame Track	372
6539 Turbocharger.....	150	Axle, 82 Inch Gauge Width.....	366
6546 Turbocharger	76	Axle, Track Louisiana Frame.....	362
7436 Air Conditioning Compressor.....	78, 152	Axle, Track, High Mount Frame.....	362
7701 Timing Gear Cover	80, 154		
7899 Air Compressor Mounting Plug.....	82, 156	B	
800CC Ground Drive, Motor GP.....	348, 350	B1 FEED ROLLER MOTOR (OPTION 5720), B2 (OPTION 1000,1020).....	900
82 Inch Gauge Width, Axle	366	B1 Feed Roller Motor, Option 5700	898
8401 Engine Wiring Harness.....	158	B2 Feed Roller Motor, Option 1010	762
8414 Engine Wiring Harness.....	84	B2 Feed Roller Motor, Option 1010, 1030	912
8903 Exhaust Gas Recirculation, EGR	160	BAR, FRAME LOCK-5926-6090HT804	72
8997 Exhaust Gas Recirculation (EGR) - Plug.....	86	Base Cutter Lift Stop	358
9801 Lift Straps	88, 162	Basecutter Chopper, Standard, Lines GP	948
9901 Replacement Engine	90, 164	Basecutter Disc GP, 22 Inches, Option 5610	868
		Basecutter Disc GP, 22 Inches, Option 95BJ	870
A		Basecutter Disc GP, 24 Inches, Option 5600	866
A/C and Heating Ducts.....	666	Basecutter Disc Shield GP {Wheel}.....	506
A/C Condenser.....	644	Basecutter Disc Shield, Wheel	506
A/C Condenser Motor.....	484	Basecutter GP, Disc 22 Inches Option 5610	868
A/C Heating and Pressurizer.....	668	Basecutter GP, Disc 22 Inches Option 95BJ	870
A/C High Pressure Switch	644	Basecutter GP, Disc 24 Inches Option 5600	866
A/C PRECLEANER.....	612	Basecutter GP, Gearbox.....	858
A/C Thermostat Switch, Wiring Harness	290	Basecutter GP, Leg, Option 5650	862
ABC Harness, Load Center.....	292	Basecutter GP, Standard Legs, Kickers	862
ABC, Attachment.....	438	Basecutter Height Indicator Mount, LH, Track.....	634
Actuator-6539-6090HT803	150	Basecutter Height Indicator Mount, Louisiana Track	632
Adjustable Roller GP, Knockdown	874	Basecutter Height Indicator Mount, RH, Track	636
Adjuster, RH Armrest Assembly	656	Basecutter Height Indicator Mount, Wheel	638
Air Cleaner.....	184	Basecutter Height Indicator, Mount, Track	632
Air Cleaner, GP.....	184		

Alphabetical Index - Continued

Page	Page		
Basecutter Leg, Breakaway Kit, Attachment.....	860	Brush Rail GP, Track	574
Basecutter Lift Counter Balance Valve, Track	446	Brushrail GP - Wheel.....	588
Basecutter Lift Cylinder and Lines, Wheel.....	478	Brushrail, Track	574
Basecutter Lift Cylinder, LH, Wheel.....	480	Bulkhead to Nozzles, Lines	660
Basecutter Lift Cylinder, RH, Wheel.....	482	Bumper, Column Stop	400
Basecutter Lift Cylinder, Track.....	452	Buttlifter Roller Gp	916
Basecutter Lift Lines, Pump To Valve, Option 3200, Wheel	434	Buttlifter Roller GP, Option 5700.....	896
Basecutter Lift Lines, Pump To Valve, Option 3210, Wheel	436	Buttlifter Roller GP, Option 5720.....	878
Basecutter Lift Suspension, Wheel.....	394		
Basecutter Lift Track, Lines	440	C	
Basecutter Lift Valve.....	496	Cab Air Filters	664
Basecutter Lift, Lines GP, Pump To Valve, Wheel.....	478	Cab Body Assembly	646
Basecutter Lift, Track, Lines	442	Cab Frame.....	646
Basecutter Motor and Hydraulic Lines.....	476	Cab Glass and Door Assembly	652
Basecutter Motor, Option 1000,1020.....	872	CAB GP, A/C PRECLEANER	612
BASECUTTER MOUNTING GP.....	856	Cab GP, Secondary Floor Mat (Option 7290).....	606
BASECUTTER PUMP WIRE HARNESS (OPTION 1000,1020)(100601-.....)	966	Cab GP, Windshield Washer, Reservoir to Bulkhead	608
Basecutter, Pump GP.....	968	Cab Harness.....	292
Basket, Elevator, Option 6000.....	924	Cab Lifting Unit, Cab GP	562
Basket, Elevator, Option 6010.....	928	Cab Monitor Harness.....	622
Battery	194	Cab Panels and Floor.....	650
Battery Box.....	194	Cab Roof Assembly.....	648
Battery Cable.....	194	Cab Seat.....	656
Beacon Light.....	230	Cab Secondary Display Module	620
Beacon Light and Harness	230	Cab Secondary Display, Display Module.....	620
Beacon Light Switch.....	230	Cab Tilt	562
Bearing Hub, Chopper GP.....	964	Cab Tilt Cylinder and Lines	464
Bearing, Crankshaft Thrust-4701-6090HT803	132	Cab Tilt Lock.....	564
Bearing, Crankshaft Thrust-4701-6090HT804	60	Cab, Flasher CE, Wiring Harness	280
Bearing, Crop Divider (Option 0911)	724	Cab, Propulsion Controls.....	670
Bearing, Crop Divider, Standard, Louisiana and Wide Track	730	Cab, Right Hand Corner Post.....	618
Bearing, Feed Roller.....	920	Cable, Ground And Battery	196
Bearings, Connecting Rod-4801-6090HT803	134	CAC GP.....	182
Bearings, Connecting Rod-4801-6090HT804	62	Cam Follower-4609-6090HT803	130
Bearings, Main-4701-6090HT803	132	Cam Follower-4609-6090HT804	58
Bearings, Main-4701-6090HT804	60	Camera, Wiring Harness	298
Beacon Light, Harness.....	296	Can Diagnostic, Harness.....	292
Belt Tensioner-6218-6090HT803.....	148	Carrier and Undercarriage Roller, Track.....	380
Belt Tensioner-6218-6090HT804.....	74	CE Certification Decals (Track).....	540
Belt, Fan-2407-6090HT803	114	CE Certification Decals (Wheel).....	542
Belt, Fan-2407-6090HT804	42	CE Certification, Decal GP, Track.....	540
Bent Shoes, 16 Inch, Sealed Chain.....	384	CE Certification, Wheel, Decals GP	542
Bent Shoes, 18 Inch Sealed Chain.....	376	CE Flasher Harness	280
Bent Shoes, 20 Inch Sealed Chain.....	374	CE Roadway, Light GP, Wheel.....	582
Bent Shoes, 20 Inch, Standard Chain, Track	386	Center Wiper Motor, Wiring Harness.....	298
Bezel, Cab Roof	648	Chain Sealed with 18 Inch Straight Shoes, Track	388
Billet Deflector	988	Chain, Elevator.....	1028
Bin Flap Lines GP, Valve To Cylinder	1074	Chain, Elevator, Option 6510.....	1012
BIN FLAP VALVE	1036	Chain, Primary Extractor Ring Rotate, Option 6100.....	980
Bin Flap Valve to Cylinder Lines.....	1074	Chain, Primary Extractor Ring Rotate, Option 6110	982
Blade, Basecutter, Option 5600	866	Chain, Secondary Extractor Hood Rotate, Option 6410, 6420.....	1084
Blade, Basecutter, Option 5610.....	868	Charge Air Cooler and Radiator Lines 3520.....	192
Blade, Basecutter, Option 95BJ.....	870	CHARGE AIR COOLER GP	182
Blade, Chopper (Option 5910).....	960	Charge Air Cooler Motor.....	484
Blade, Chopper (Option 95BB).....	962	Charged Air Cooler and Radiator Lines.....	190
Blade, Primary Extractor.....	984	Chassis Harness	290
Blade, Secondary Extractor GP (Option 6410,6420).....	1090	Chassis Wiring Harness	232
Blade, Topper	674, 678	Chemical Type Fire Extinguisher.....	510
Blade, Topper, Option 5020.....	680	Chopper Curtain Agitator GP, Option 7170, Track.....	940
Block, Cylinder-4601-6090HT803	129	Chopper Curtain Agitator Lines GP Option 7170, Track	944
Block, Cylinder-4601-6090HT804	57	Chopper Curtain Agitator Motor, Option 7170, Track	952
Block, Cylinder-4609-6090HT803	130	Chopper Curtain GP, Rigid Mount, Option 9170, Track.....	934
Block, Cylinder-4609-6090HT804	58	Chopper Curtain GP, Rigid Mount, Track	940
Blower Motor.....	668	Chopper Curtain GP, Rubber (Wheel).....	936
Boom, Topper.....	672	Chopper Curtain GP, Rubber, Option 0911, Track.....	932
BOTTOM FEED ROLLER MOTOR (B2,B3,B4,B5).....	914	Chopper Curtain GP, Rubber, Track	938
Bracket, Alternator Mounting-6218-6090HT803.....	148	Chopper GP, Bearing Hub	964
Bracket, Alternator Mounting-6218-6090HT804.....	74	Chopper GP, Clutch.....	976
Bracket, Flasher Harness.....	278	Chopper GP, Gearbox, Option 1000, 1020.....	954
Bracket, Surge Tank	190	Chopper GP, Gearbox, Option 1010, 1030.....	956
Bracket, Surge Tank 3520	192	Chopper GP, Shaft Eight Blade (Option 5910)	960
Bracket, Upper Radiator Hose Mount.....	190	Chopper GP, Shaft Eight Blade (Option 95BB)	962
Bracket, Wiring Harness-8414-6090HT804.....	84	Chopper GP, Shaft Eight Blade, Option 5900	960
Brake Pedals, Wheel.....	210	Chopper GP, Shaft Eight Blade, Option 95BB, 5920	962
Brake, Park, Lines GP.....	414	Chopper GP, Shaft Six Blade, Option 5910	958
Break A Way Toe.....	734	Chopper Kit, Attachment	946
Break Away Basecutter Leg GP, Option 7020	864	Chopper Motor, Option 1000,1020	950
Breakaway Kit, Basecutter Leg, Attachment	860	CHOPPER PUMP WIRE HARNESS(OPTION 1000, 1020)(100601-.....)	966
Breather, Fuel Tank	178	Chopper Sill GP, Option 6000.....	924
Breather, Lines GP, Chopper.....	990	Chopper Sill GP, Option 6010.....	928
Breather-2902-6090HT803.....	118		
Breather-2902-6090HT804.....	46		

Alphabetical Index - Continued

<i>Page</i>	<i>Page</i>		
Chopper Sill, Louisiana, Curtain Rubber	942	Cover, Water Pump Inlet-5708-6090HT804	71
Chopper, Basecutter Lines	948	Crank Oil Seal-7701-6090HT803	154
Chopper, Basecutter Pump, Option 1000, 1020	972	Crank Oil Seal-7701-6090HT804	80
Chopper, Basecutter Pump, Option 1000, 1020, (Cont.)	974	Crankshaft and Bearing-4701-6090HT803	132
Chopper, HP Pump	970	Crankshaft and Bearing-4701-6090HT804	60
Chopper, Lines GP	990	Crankshaft Oil Seal-1405-6090HT803	100
Chopper, Retainer Sill	938	Crankshaft Position Sensor-4609-6090HT803	130
Chopper, Sill Roller, Attachment	926	Crankshaft Position Sensor-4609-6090HT804	58
CHOPPER/BASECUTTER PUMP WIRE HARNESS (OPTION		Crankshaft Pulley and Damper-1303-6090HT803	98
1000,1020)(100601-)	966	Crankshaft Pulley and Damper-1303-6090HT804	28
Closed Buttlifter Roller GP, Option 5700	896	Crankshaft Rear Oil Seal-1405-6090HT804	29
Clutch, Chopper GP	976	Crankshaft Thrust Bearing-4701-6090HT803	132
CMRV India, Harness, Main Frame	234	Crankshaft Thrust Bearing-4701-6090HT804	60
COLLECTOR MOTOR (OPTION 5000,5010,5020)	704, 1046	Crankshaft-4701-6090HT803	132
Column Lower Housing	400	Crankshaft-4701-6090HT804	60
Column Stop Bumper	400	Crop Divider (Inner) Pump	492
Compact 2K, 4K, Standard Motor	786	Crop Divider and Front Hydraulic Tilt, Attachment	748
Compartment, Engine, Door GP	566	Crop Divider Bearing (Option 0911)	724
Compressor, Air Conditioning-7436-6090HT803	152	Crop Divider Break A Way Toe	734
Compressor, Air Conditioning-7436-6090HT804	78	Crop Divider Cover W/o Row Sense Sensor	732
Condenser Frame	630	Crop Divider Float Harness	264
Condenser Guide, Structural GP	630	Crop Divider Float Relay	264
CONDENSER/FUEL COOLER GP	182	Crop Divider Float Switch	264
Connecting Rod Bearing-4801-6090HT803	134	Crop Divider Floating Shoe, Louisiana	714
Connecting Rod Bearing-4801-6090HT804	62	Crop Divider Gauge Wheel	740
Connecting Rods-4801-6090HT803	134	Crop Divider GP, Knockdown (Option 5510, 5520, 5530)	794
Connecting Rods-4801-6090HT804	62	Crop Divider GP, Knockdown, Option 5510,5520,5530	794
Console, Seat Support	666	Crop Divider Grease, Lines	838
Container RH Storage	652	Crop Divider Hydraulic Tilt, Attachment	754
Control GP, Autotrac Pedal (Option 7310,7320) (Track)	610	Crop Divider Knock Down Roller Lines GP	792
Control GP, Ground Drive, High/Low (Option 95Bl) (-090755)	316	CROP DIVIDER KNOCKDOWN ROLLER LINES GP (OPTION	
Control GP, Ground Drive, High/Low, Option 95Bl	316	5520,5530) {WHEEL}	782
Control GP, Positrac, Wheel	332	Crop Divider Knockdown Roller, Motor, Option 5510, 5520	848
Control Switches, Floor Control	626	Crop Divider Lift	722
Control Valve, Crop Divider Float	460	CROP DIVIDER LIFT LINES GP, VALVE TO CYLINDER (OPTION	
Control Valve, Fuel Injection Pump-1601-6090HT803	104	0501,0511) - WORLD	816
Control Valve, Fuel Injection Pump-1601-6090HT804	32	CROP DIVIDER LIFT LINES GP, VALVE TO CYLINDER (OPTION	
Control, Speedometer, Wheel	615	0501,0511)-LOUISIANA	818
Controller, Engine-8401-6090HT803	158	Crop Divider Lift Valve	496
Controller, Vehicle	281	Crop Divider Lift, Hydraulic	720, 722
Controls, Elevator Operator	626	Crop Divider Lift, Hydraulic, Track	720
Controls, Ground Drive, Wheel	210	Crop Divider Lift, Manual, Standard	718
Convex Mirror	578	Crop Divider Lift, Manual, Track	716
Convex, Mirror	578	Crop Divider Lift, Standard	718
Coolant Heater Plug-2699-6090HT803	115	Crop Divider Lift, Track	716, 720
Coolant Heater Plug-2699-6090HT804	43	Crop Divider Lift, Track, Manual	716
Coolant Temperature Sensor-3902-6090HT803	124	Crop Divider Lines GP, Left , Option 5510, 5520, Wheel	832
Coolant Temperature Sensor-3902-6090HT804	52	Crop Divider Lines GP, Left (Option 5300,5310) Track	828
Cooler, Engine Oil-5901-6090HT803	146	CROP DIVIDER LINES GP, LEFT (OPTION 5530) {WHEEL}	790
Cooler, Oil-5926-6090HT804	72	Crop Divider Lines GP, Left, Option 5300, 5310, Wheel	830
Cooling Fan Mount GP (Option 1020,1030)	568	CROP DIVIDER LINES GP, RIGHT (OPTION 5300) {TRACK}	760
Cooling Fan Mount, 6 Blade, Tier 2	592	Crop Divider Lines GP, Right, Option 5510, Wheel	834
Cooling Fan Mount, 8 Blade, Tier 3	568	Crop Divider Louisiana, MESA	726
Cooling Fan, Mount GP	592	Crop Divider Scroll Mount, RH	742
Cooling Package Fan-Motor Relief Valve	470	Crop Divider Sensor and Mountings	640, 854
Cooling Package Fan-Pump to Motor Lines	470	Crop divider Shield, Without Knock Down Rollers	712
Cooling Package Harness and Connectors	288	Crop Divider Slip On Shoe With Gauge Wheel	734
Cooling Package Motor	484	Crop Divider Slip On Shoe, MESA	736
Cooling Package MY12, Harness	288	Crop Divider Tilt Cylinder, Option 5210	894
Cooling Package Structural GP, Condenser Guide	630	Crop Divider Tilt Lines GP, Valve To Cyl (Opt 5210)	822
Cooling Package, Engine (- XXXXXX)	282	Crop Divider Tilt Lines GP, Valve to Cylinder, Option 5210	824
Cooling Package, Engine (XXXXXX -)	284	Crop Divider Vine Knife Mount GP (Option 9030)	852
Cooling Package, Front and Side Pannels	576	Crop Divider W/O Scroll, Wheel, Lines GP	788
Cooling Screen GP, Rear	572	Crop Divider, 3520 Wheel	738
Corner Post, Cab, Right Hand	618	Crop Divider, CD KD, Rollers, Attachment	776
Counter Balance Valve, Basecutter Lift, Track	446	Crop Divider, Dual, Side Knife, lines GP	784
Coupler Assembly, Steering Shaft	402	Crop Divider, Dual, W/CDKD, Lines GP, Left	780
Coupling Drive	174	Crop Divider, Elevator Pump	490
Cover and Shield GP, Engine Compartment	594	Crop Divider, Floating Shoe	714
Cover Assy, Dome Light	648	Crop Divider, Floating Shoe, Louisiana	714
Cover GP, Shield, Engine Compartment	594	Crop Divider, Gauge Wheel Hub	740
Cover, Barrier, Panel	650	Crop Divider, Louisiana Option	724
Cover, Exhaust	186	Crop Divider, Louisiana, Track	724, 726
Cover, Resonator	648	Crop Divider, MESA	728
Cover, Rocker Arm-1102-6090HT803	96	Crop Divider, Outer, Motor, Option 5310, 5320, 5330	850, 918
Cover, Rocker Arm-1102-6090HT804	26	Crop Divider, Right Hand, Lines GP, Wheel	798
Cover, Steering Wheel	400	Crop Divider, Side Knife GP, Left, Option 5330	812
Cover, Thermostat-2107-6090HT803	111	Crop Divider, Slip On Shoe	734
Cover, Thermostat-2107-6090HT804	39	Crop Divider, Slip On Shoe, with Gauge Wheel	734
Cover, Timing Gear-7701-6090HT803	154	Crop Divider, Standard, Louisiana, Wide Track	730
Cover, Timing Gear-7701-6090HT804	80	Crop Divider, Top Link, Standard, Track	716
Cover, Valve-1102-6090HT803	96	Crop Divider, Track, Louisiana	724
Cover, Valve-1102-6090HT804	26	Crop Divider, Track, MESA	726

Alphabetical Index - Continued

Page	Page		
Crop Divider, W/O Scroll, Lines GP, Left, Wheel.....	804	Drive Pump Gearbox.....	170
Crop Divider, Weld Parallel.....	728	Drive Sprocket, Track.....	382
Crop Divider, Weld Parallel, MESA.....	728	Drive, Fan-2321-6090HT803.....	113
Crop Divider, Wheel.....	738	Drive, Fan-2321-6090HT804.....	41
Curtain GP, Chopper Sill, Louisiana, Track.....	942	Drive, Final Planetary.....	390
Curtain GP, Chopper, Rigid Mount, Option 9170, Track.....	934	Drive, Planetary Final Drive.....	392, 393
Curtain GP, Chopper, Rigid Mount, Track.....	934	Dual Crop Divider W/CDKD, Lines GP, Left.....	780
Curtain GP, Chopper, Rubber.....	936	Dual Crop Divider, Right Hand, Lines GP.....	784
Curtain GP, Chopper, Rubber Option, Wheel.....	932	Ducts Blower.....	666
Curtain GP, Chopper, Rubber, Option 0911, Track.....	932	Dust Shield.....	668
Curtain GP, Chopper, Rubber, Track.....	938		
Cylinder Block Fittings-5299-6090HT803.....	142	E	
Cylinder Block Fittings-5299-6090HT804.....	70	ECU-8401-6090HT803.....	158
Cylinder Block-4601-6090HT803.....	129	EGR Cooler-8903-6090HT803.....	160
Cylinder Block-4601-6090HT804.....	57	EGR Valve-8903-6090HT803.....	160
Cylinder Block-4609-6090HT803.....	130	EGR-8903-6090HT803.....	160
Cylinder Block-4609-6090HT804.....	58	Electrical connector.....	922
Cylinder Function Valve.....	496	Electrical GP, ABC Wiring Harness, Attachment.....	438
Cylinder Function Valve, 6 Bank.....	496	Electrical GP, Engine Computer.....	212
Cylinder Head Kit-5101-6090HT803.....	140	Electrical Harness Diode, Cab.....	294
Cylinder Head Kit-5101-6090HT804.....	68	Electrical Harness, Main Frame Extension.....	248
Cylinder Head-5101-6090HT803.....	140	Electrical Switch (Option 95BI).....	300
Cylinder Head-5101-6090HT804.....	68	Electrical, Extension Main Frame.....	250
Cylinder Liner Packing-4801-6090HT803.....	134	Electrical, Fuses And Relays.....	228
Cylinder Liner Packing-4801-6090HT804.....	62	Electrical, Main Frame.....	244
Cylinder Liner-4609-6090HT803.....	130	Electronic Control Unit, ECU-8414-6090HT804.....	84
Cylinder Liner-4609-6090HT804.....	58	Element, Oil Filter-5926-6090HT804.....	72
Cylinder Lines GP Elevator Extension Frame To Valve (Option 6530).....	1058	Elevator 24 Inch Extension, Attachment (Track) (1 of 3).....	1062
Cylinder, Basecutter Lift, RH, Wheel.....	482	Elevator 24 Inch Extension, Attachment (Track) (2 of 3).....	1064
Cylinder, Basecutter Lift Lines, 3520, Track.....	448	Elevator 24 Inch Extension, Attachment (Track) (3 of 3).....	1066
Cylinder, Basecutter Lift, LH, Wheel.....	480	Elevator 34 Inch Extension (Track).....	1072
Cylinder, Basecutter Lift, Track.....	452	Elevator 34 Inch Extension Lines (Track).....	1080
Cylinder, Basecutter Lift, Wheel.....	478	Elevator 34 Inch Extension, Attachment (Track)(1 of 2).....	1068
Cylinder, Cab Tilt.....	464	Elevator 34 Inch Extension, Attachment (Track)(2 of 2).....	1070
Cylinder, Crop Divider Float, Option 7800.....	844	Elevator Basket, Option 6000.....	924
Cylinder, Crop Divider Tilt, Option 5210.....	894	Elevator Basket, Option 6010.....	928
Cylinder, Topper Lift.....	708	Elevator Chain GP, Extension 12 Inches, Option 6510.....	1012
Cylinder-Crop Divider Float, Option 7800.....	844	Elevator Chain GP, Extension 24 Inches, Option 6520, Track.....	1018
		Elevator Chain GP, Extension 34 Inches, Option 6520, Track.....	1072
D		Elevator Discharge Chute.....	1082
Daily Service Tool Kit.....	600	ELEVATOR DRIVE LINES GP, VALVE TO MOTOR.....	1042
Daily Service Tools, Attachment.....	596	Elevator Drive Pump.....	492
Dampener-1303-6090HT803.....	98	Elevator Drive Pump Lines, Feed Roller To Inner Crop Divider.....	488
Dampener-1303-6090HT804.....	28	Elevator Drive Pump, Feed Roller to Inner Crop Divider.....	492
Damper-1303-6090HT803.....	98	ELEVATOR DRIVE VALVE.....	1036
Damper-1303-6090HT804.....	28	Elevator Drive, Feed Roller To Crop Divider Inner Lines.....	488
Debris Shield GP (Wheel).....	506	Elevator Drive, Lines GP, Variable.....	1044
Decal GP, 3520.....	520, 522	Elevator Extension 12 Inches, Option 6510.....	1012
Decal GP, 3520 French.....	524, 526	Elevator Extension 24 Inches, Option 6520, Track.....	1018
Decal GP, English Option 6700, Frame, Wheel.....	534	Elevator Extension 34 Inches, Option 6520, Track.....	1072
Decal GP, Spanish, Option 6700, Frame, Wheel.....	530, 532	Elevator Extension Cylinder Lines Frame To Valve (Option 6530).....	1058
Decal, English, Wheel.....	534	Elevator Extension Lines GP, Frame To Valve (Option 6510).....	1024
Decal, French, Track.....	524, 526	Elevator Extension Lines GP, Frame To Valve, Option 6520.....	1026
Decal, French, Wheel.....	528	Elevator Extension Main Frame, Electrical GP.....	252
Decal, India, Wheel.....	538	Elevator Extension, 12 Inches, Attachment.....	1056
Decal, Label.....	512, 514	Elevator Extension, 34 Inches (Track).....	1078
Decal, Spanish, Wheel.....	530, 532	Elevator Flood Light and Harness.....	260
Decals.....	536	Elevator Floor GP, Lower Section.....	1020
Decals GP.....	516	Elevator Floor GP, Upper Section (Option 6500).....	1076
Decals, English, Track.....	520, 522	Elevator Floors GP, Extension 24 Inches, Option 6520, Track.....	1018
Decals, No Text, Track.....	550	Elevator Floors Gp, Extension 34 Inches, Option 6520, Track.....	1072
Decals, No Text, Wheel.....	546	Elevator GP, Attachment.....	1008
Decals, Portuguese, Track.....	516, 518	Elevator GP, Chain.....	1028
Decals, Spanish, Track.....	512, 514	Elevator GP, Drive, Sprocket, Chain and Slats.....	1028
Deep Paddle Roller GP Feed, B2, B3, B4, B5.....	880	Elevator GP, Extension 12 Inches, Attachment.....	1016
Deflector, Billet.....	988	Elevator GP, Extension 12 Inches, Option 6510.....	1012
Deluxe Tools, Attachment.....	598	Elevator GP, Extension 24 Inches, Option 6520, Track.....	1018
Diode Wiring Harness, Cab.....	294	Elevator GP, Main Frame, Shield, Flaps.....	1010
Dipstick-4028-6090HT803.....	126	Elevator GP, Wearstrip And Floor, Lower Section (Option 6500).....	1076
Dipstick-4028-6090HT804.....	54	Elevator GP, Weather Strip and Floor, Lower Section.....	1020
Disc 24 Inch, Basecutter GP.....	866	Elevator Harness.....	262
Display Module, Right Hand Corner Post, Cab.....	618	Elevator Harness and Connectors.....	262
Divider, Crop, Lines GP, Right Wheel.....	798	Elevator HP, Lines.....	1032
Door Assembly, Cab.....	652	ELEVATOR LIFT LINES GP.....	1048
Doubler, Primary Extractor.....	984	ELEVATOR LIFT VALVE.....	1036
Drain Hoses, Engine and Pump Drive.....	176	Elevator Lines GP, Main Frame To Swing Table.....	1038
Drain Plug, Fuel Tank.....	178	Elevator Lines GP, Swing Table to Top Elevator Frame.....	1030
Drive Coupling.....	174	Elevator Operator Controls.....	626
Drive GP, Elevator, Sprocket, Chain And Slats.....	1028	Elevator Sheave GP.....	1008
Drive Motor Ground GP, Option Hi/Low, Track.....	326	Elevator Swing Lines GP, Valve to Cylinder.....	1040
		Elevator Swing Table.....	1008

Alphabetical Index - Continued

Page	Page
Elevator Swing Table, Option 7620	1006
Elevator Swing Valve	496
Elevator Wearstrip and Floor, Upper	1076
Elevator Wearstrip GP, Extension 12 Inches	1012
Elevator Wearstrip GP, Extension 24 Inches, Option 6520, Track ..	1018
Elevator Wearstrip GP, Lower Section	1020
Elevator Wearstrip GP, Upper Section (Option 6500)	1076
Elevator Weather Strip GP, Extension 34 Inches, Option 6520, Track	1072
Elevator, Electrical GP	260
Elevator, Frame to Valve Lines GP	1022
Elevator, Lines GP, Pump To Swing Table	1060
Elevator, Pump, Crop Divider	490
Engine	168
Engine Accessories, 6090 Engine Tire III	168
Engine Accessories, 6090 Engine, Tire II	166
Engine Accessories, Tier III 6090	166, 168
Engine and Pump Drive Drain GP	176
ENGINE COMPARTMENT DOOR GP	566
Engine Compartment Door Switch	212
Engine Compartment Doors	566
Engine Compartment Shields	594
Engine Compartment, Shield, Cover GP	594
Engine Controller-8401-6090HT803	158
Engine Cooling Harness (- XXXXXX)	282
Engine Cooling Harness (XXXXXX -)	284
Engine Cooling Package, Electrical GP (- XXXXXX)	282
Engine Cooling Package, Electrical GP (XXXXXX -)	284
Engine Fan	166, 168
Engine Harness	222, 224
Engine Harness and Mounting	212
Engine Heater Hose	628
Engine Mount	172
ENGINE MOUNT GP	172
Engine Oil Cooler-5926-6090HT804	72
Engine Oil Filter-5926-6090HT804	72
Engine Oil Pressure Sensor-4609-6090HT803	130
Engine Oil Pressure Sensor-4609-6090HT804	58
Engine Wiring Harness and Connectors .. 214, 216, 218, 220, 222, 224	214, 216, 218, 220, 222, 224
Engine Wiring Harness and Connectors (1of6)	214
Engine Wiring Harness and Connectors (2of6)	216
Engine Wiring Harness and Connectors (3of6)	218
Engine Wiring Harness and Connectors (4of6)	220
Engine Wiring Harness and Connectors (5of6)	222
Engine Wiring Harness and Connectors (6of6)	224
Engine Wiring Harness-8401-6090HT803	158
Engine Work Light Switch, Harness	298
Engine, Main Harness	292
Engine, Replacement-9901-6090HT803	164
Engine, Replacement-9901-6090HT804	90
Engine, Sensors	212
English Option 6700, Decal GP, Wheel	534
Evaporator Heater Assy	668
Evaporator, Filter	664
Exhaust Cover	186
Exhaust Gas Recirculation (EGR) - Plug-8997-6090HT804	86
Exhaust Gas Recirculation-8903-6090HT803	160
Exhaust Manifold-2814-6090HT804	44
Exhaust Valve-5101-6090HT803	140
Exhaust Valve-5101-6090HT804	68
Extension Main Frame, Elevator, Electrical GP	252
Extension Ring, Primary Extension, Option 6100	980
Extension Ring, Primary Extension, Option 6110	982
Extension, 24 Inches, Elevator, Attachment	1064
Extension, Elevator, Attachment	1016
Extension, Main Frame, Wiring Harness	254
Exterior Front Panel GP Assembly	576
Extinguisher, Fire	510
F	
Fan Belt-2407-6090HT803	114
Fan Belt-2407-6090HT804	42
Fan Drive-2321-6090HT803	113
Fan Drive-2321-6090HT804	41
Fan, Alternator-3121-6090HT803	121
Fan, Alternator-3121-6090HT804	49
Fan, Cooling (Option 1020,1030)	568
Fan, Engine	166, 168
Feed Circuit Valve, Front	500
Feed Lower , Pipe Rollers GP	882
Feed Lower, 4 Bar Roller GP	880
Feed Roller Bearing	920
Feed Roller Control GP	910
Feed Roller Flow Divider Valve, Rear	892
Feed Roller GP Deep Paddle, B2, B3, B4, B5	880
Feed Roller GP, B2, B3, B4, B5, Option 95BF	882
Feed Roller GP, Upper, T1, T2, T3, T4, T5	920
Feed Roller Lines GP, RH, Option 7250 With 1000,1020	890
Feed Roller Lines GP, RH, Option 7250 with 1010, 1030	886
FEED ROLLER MOTOR B1 (OPTION 5720), B2 (OPTION 1000,1020)	900
Feed Roller Motor B1, Option 5700	898
Feed Roller Motor B2, Option 1010	762
Feed Roller Pump	492
Feed Roller, Left, Lines GP	888
Feed Roller, Rear, Valve GP	906
Feed Rollers, Upper, T1, T2, T3, T4, T5	920
Field Lamp, Harness	296
Field Reinforcement	604
Filter and Sensor, Hydraulic Tank	430
Filter Element	664
Filter, Fuel Lines, 30 Micron	188
Filter, Fuel-3510-6090HT803	122
Filter, Fuel-3510-6090HT804	50
Filter, Hydraulic	432
Filter, Oil-5901-6090HT803	146
Filter, Oil-5926-6090HT804	72
Final Drive, Iberica Track	392
Final Drive, Planetary	390
Final Drive, Track	393
Final Drive, Track, Iberica	392, 393
Finned Roller Lines GP, Option 5310, 5320, 5330	902
Fire Extinguisher	510
Firestone Tire Front, Wheel	398
Fittings, Cylinder Block-5299-6090HT803	142
Fittings, Cylinder Block-5299-6090HT804	70
Flange Split, Ground Drive, Motor Gp	346
Flasher Harness and Support, Wheel	278
Flasher Module, Wiring Harness	298
Flasher Relay	278
Flexible Crop Divider Sensor and Mountings	854
Floating Crop Divider Harness	242
Floating Crop Divider Lines GP, Option 78 00	844
Floating Crop Divider Position Sensor and Mounting	640
Floating Crop Divider Position Sensor and Mounting, MESA	640
Flood Lamp, Head Liner	648
Floodlamp	260
Floor and Panel, Cab GP	650
Floor Mat, Cab GP	606
Flow Divider Valve, Rear Feed Roller	892
Flywheel Housing-1405-6090HT804	29
Flywheel-1505-6090HT803	102
Flywheel-1505-6090HT804	30
Follower, Cam-4609-6090HT803	130
Follower, Cam-4609-6090HT804	58
Four Bank Auxiliary Tilt Function Valve	750
Four Bank Manifold, Valve GP (Option 5210)	498
Frame Assembly, Crop Divider	738
Frame Assy B-Post RH	646
Frame Decal GP, French Option 6720, Wheel	528
Frame Track, Standard	368
Frame, Cab	646
Frame, CMRV, CE, Wiring Harness	240
French Frame Decal, Option 6720	528
Front Feed Circuit, Valve	500
Front Oil Seal-7701-6090HT803	154
Front Oil Seal-7701-6090HT804	80
Front Panel GP Assembly, Exterior	576
Front Tube Cab Frame Assy	646
Front Turn Signal Light, Standard	198
Front Turn Signal Lights, Standard	198
Front Turn Signal, Wiring Harness	236
Front Wheel Firestone Tire	398
Front Wheel, Firestone	398
Front Wheel, Firestone Tire	398
Fuel and Water Separator-3510-6090HT803	122
Fuel and Water Separator-3510-6090HT804	50
Fuel Cooler Motor	484
FUEL COOLER/CONDENSER GP	182
Fuel Filter and Lines, 30 Micron	188
Fuel Filter-3510-6090HT803	122
Fuel Filter-3510-6090HT804	50
Fuel Injection Nozzle-1601-6090HT803	104
Fuel Injection Nozzle-1601-6090HT804	32

Alphabetical Index - Continued

Page	Page		
Fuel Injection Pump-1601-6090HT803.....	104	Guard, Height Indicator, Wheel.....	638
Fuel Injection Pump-1601-6090HT804.....	32	Guard, High Mount Track.....	370
Fuel Level Sensor.....	212	Guide, Cab GP.....	562
Fuel Lines and Filter, 30 Micron.....	188		
Fuel Lines-1601-6090HT803.....	104	H	
Fuel Lines-1601-6090HT804.....	32	Hand, Pump GP, Rotary.....	504
Fuel Pump, Fuel Filter-3510-6090HT803.....	122	Handle, Window.....	658
Fuel Pump, Fuel Filter-3510-6090HT804.....	50	Harness and Switches, Armrest, Track (SN.-121024) (- 121024).....	270
Fuel Rail Pressure Sensor-1601-6090HT803.....	104	Harness and Switches, Armrest, Track (SN.121210-) (121210 -).....	272
Fuel Rail Pressure Sensor-1601-6090HT804.....	32	Harness and Switches, Armrest, Wheel (SN.121210-) (121210 -).....	276
Fuel Tank.....	178	Harness and Switches, Operator Armrest, Wheel (SN.-121024) (- 121024).....	274
Fuel Tank Plastic, Mount GP.....	180	Harness HID, Jumper.....	206
Fuel Temperature Sensor-1601-6090HT803.....	104	Harness Load Center, Cab.....	294
Fuel Temperature Sensor-1601-6090HT804.....	32	Harness, Alternator Wiring-3121-6090HT803.....	121
Fuel, Tank GP.....	178	Harness, Alternator Wiring-3121-6090HT804.....	49
Fuses And Relays.....	228	Harness, Beacon Light.....	230
		Harness, CE, CMRV Frame.....	240
G		Harness, Crop Divider Float.....	264
Gas Operated Cylinder, Window.....	658	Harness, Elevator, Connectors.....	262
Gasket, Air Intake-1707-6090HT804.....	34	Harness, Engine Wiring-8401-6090HT803.....	158
Gasket, Exhaust Manifold-2802-6090HT803.....	116	Harness, Extension Main Track.....	258
Gasket, Exhaust Manifold-2814-6090HT804.....	44	Harness, Primary Extension Jumper (- XXXXXX).....	266
Gasket, Rocker Arm Cover-1102-6090HT803.....	96	Harness, Primary Extension Jumper (XXXXXX -).....	267
Gasket, Rocker Arm Cover-1102-6090HT804.....	26	Harness, Turn Signal.....	200
Gasket, Turbocharger-6546-6090HT804.....	76	Head Light Wiring Harness.....	238
Gauge Wheel Hub, Crop Divider.....	740	Head, Cylinder-5101-6090HT803.....	140
Gear, Crankshaft-4701-6090HT803.....	132	Head, Cylinder-5101-6090HT804.....	68
Gear, Crankshaft-4701-6090HT804.....	60	Heat Exchange Core.....	182
Gear, Fuel Injection Pump-1601-6090HT803.....	104	Heat Exchanger.....	668
Gear, Fuel Injection Pump-1601-6090HT804.....	32	Heater Hose GP, Engine.....	628
Gear, Oil Pump (004977 -)-5003-6090HT803.....	139	Heater Plug-2699-6090HT803.....	115
Gear, Oil Pump (004977 -)-5003-6090HT804.....	67	Heater Plug-2699-6090HT804.....	43
Gear, Segment Lock, Steering.....	402	Height Indicator, LH.....	634
Gearbox Basecutter GP.....	858	Height Indicator, RH.....	636
Gearbox Chopper GP, Option 1000, 1020.....	954	Height Indicator, Track.....	634, 636
Gearbox Chopper GP, Option 1010, 1030.....	956	Hi/Low option, Motor, Ground Drive, Left Track.....	330
Gearbox, Pump Drive.....	170	HID Front Work Lights.....	226
Glass and Door, Cab Assembly.....	652	HID Front Work Lights And Harness.....	226
GP Lines, RH Dual Crop Divider.....	784	HID Lamp.....	226
GP Mounting, Receiver.....	614	HID Light, Side Work.....	204
GP Pump, 5 Section Pump.....	494	High Intensity Side Work Light.....	204
Grain Drive Track, Lines.....	324	High Low Switches, Electrical.....	300
Graphics Panel, Radio W/O Mirror Switch.....	654	High Mount Frame, Axle, Track.....	362
GREASE LINES GP, PRIMARY EXTRACTOR RING.....	978	High Mount Frame, Track.....	370
Greenstar™ Mounting.....	614	High Mount Frame, Track, Axle.....	362
Ground and Battery Cable.....	196	High Mount Track Frame, Louisiana.....	370
Ground Drive Controls, Wheel.....	210	High Mount Track Guard.....	370
Ground Drive Half Track, Lines.....	306	High Mount, Track Frame.....	370
Ground Drive High/Low Switch (Track).....	300	High/Low Ground Drive Control GP (Option 95BI)(-090755).....	316
Ground Drive Hydraulic Lines.....	474	Hood Rotate Lines, Primary Extractor, Valve to Motor.....	1002
Ground Drive Motor (1 of 2).....	348	Hood Rotate, Primary Extractor, Motor.....	1004
Ground Drive Motor (2 of 2).....	350	Horn.....	256
GROUND DRIVE MOTOR {WHEEL}.....	354	Horn and Light Brackets.....	256
GROUND DRIVE MOTOR {WHEEL} (CONT.).....	356	Horn and Speakers, Harness.....	296
Ground Drive Motor and Fittings.....	346	Housing Motor Standard, Compact.....	786
Ground Drive Motor CE India.....	352	Housing, Column Lower.....	400
Ground Drive Motor GP, Option Hi/Low, Track.....	326	Housing, Flywheel-1405-6090HT803.....	100
Ground Drive Motor, Left Hi/Low Option, Track.....	330	Housing, Flywheel-1405-6090HT804.....	29
Ground Drive Motor, Left, Option Hi/Low, Track.....	328	Housing, Secondary Extractor.....	1088
Ground Drive Motor, Track.....	318	Housing, Thermostat-3902-6090HT803.....	124
Ground Drive Motor, Wheel (1 of 2).....	354	Housing, Thermostat-3902-6090HT804.....	52
Ground Drive Motor, Wheel (2 of 2).....	356	HP Pump, Chopper.....	970
GROUND DRIVE PUMP, LEFT (TRACK).....	312	Hydraulic Accumulator, Basecutter Lift.....	478
Ground Drive Pump, Left, Wheel.....	342	Hydraulic Cylinder, Crop Divider Lift, Louisiana Option 0510, 0511.....	820
Ground Drive Pump, Left, Wheel (Cont.).....	344	Hydraulic Filter.....	432
Ground Drive Pump, Right {Wheel}.....	338	Hydraulic Filter, Tank.....	430
Ground Drive Pump, Right, Wheel.....	340	Hydraulic Knockdown Tilt, Lines GP.....	884
Ground Drive, High/Low Control GP (Option 95BI)(-090755).....	316	Hydraulic Lines, 6-Bank to 4-Bank.....	752
Ground Drive, Hydraulic Lines.....	474	Hydraulic Motor, Ground Drive, Wheel.....	352
Ground Drive, Lines GP (Option 0911) {Track} (100601-).....	308	Hydraulic Oil Cooler Lines.....	466, 468
Ground Drive, Lines GP, Tank-Pump-Motor (Option 95BI) (Track).....	322	Hydraulic Oil Cooler Lines, Louisiana.....	468
Ground Drive, Lines GP, Tank-Pump-Motor, Option 95BI, Track, (100601-).....	304	Hydraulic Oil Cooler Lines, Standard.....	466
GROUND DRIVE, MOTOR {TRACK}.....	320	Hydraulic Oil Level Switch.....	426
Ground Drive, Motor GP.....	346	Hydraulic Pressure Switch.....	426
Ground Drive, Motor GP, Wheel.....	352	Hydraulic Pump Suction Lines.....	486
Ground Drive, Motor, Track.....	302	Hydraulic Pump, Feed Roller to Crop Divider Inner.....	488
GROUND DRIVE, MOTOR{TRACK}.....	320	Hydraulic Tank.....	426
Ground Drive, Pump GP (Track).....	310	Hydraulic Tank, Filter and Sensors.....	430
Ground Drive, Pump GP, Wheel.....	336	Hydraulic, Crop Divider Lift.....	722
Guard Harness, Light GP, Wheel.....	584	Hydrostatic Motor, Ground Drive, Track.....	318

Alphabetical Index - Continued

Page	Page
I	
Idler.....	378
India Wheel Decal.....	538
Injection Nozzle Kit-1601-6090HT803.....	104
Injection Nozzle Kit-1601-6090HT804.....	32
Injection Nozzle, Fuel-1601-6090HT803.....	104
Injection Nozzle, Fuel-1601-6090HT804.....	32
Injection Pump, Fuel-1601-6090HT803.....	104
Injection Pump, Fuel-1601-6090HT804.....	32
Injector Wiring Harness-1601-6090HT803.....	104
Injector Wiring Harness-1601-6090HT804.....	32
Inlet, Water Pump-5701-6090HT803.....	144
Inlet, Water Pump-5708-6090HT804.....	71
Inner Crop Divider Motor, Option 5310, 5320, 5330.....	846
Inner Scroll Lines GP, Pump To Valve (0501) (Wheel).....	758
Inner Scroll Lines, Pump to Valve, Track.....	756
Inner Scroll Lines, Track.....	756
Input Control, Steering Wheel.....	420
Instruction Reflectors, Decals GP.....	542
Instrument, Secondary Display, Cab.....	620
Intake Manifold-1701-6090HT803.....	106
Intake Manifold-1707-6090HT804.....	34
Intake Valve-5101-6090HT803.....	140
Intake Valve-5101-6090HT804.....	68
Intake, Oil Pump-1901-6090HT803.....	108
Intake, Oil Pump-1901-6090HT804.....	36
Isolator, Fan Motor.....	668
J	
Jumper Remote.....	196
Jumper, Harness HID.....	206
K	
Kit Elevator Extension, Attachment.....	1014
Kit, Basecutter Break Away Leg.....	864
Kit, Chopper, Attachment.....	946
Knockdown Crop Divider GP (Option 5510, 5520,5530).....	794
Knockdown Roller GP, Adjustable.....	874
Knockdown Roller GP, Option 5200.....	876
Knockdown Roller Lines GP, Option 5310, 5320, 5330.....	902
Knockdown Roller Lines GP, Tilt, Option 5210.....	884
Knockdown Roller Motor, Fixed.....	836, 904
L	
Labels.....	536
Ladder Assembly Left And Right Hand, Platform GP.....	590
Left Hand Scroll, W/CDKD, Lines GP, Track.....	778
Left Turn Light, Harness.....	200
Left, Dual Crop Divider W/CDKD, Lines GP.....	780
Left, Feed Roller, Lines GP.....	888
Left, Lines GP, Crop Divider, W/O Scroll, Wheel.....	804
Left, Side Knife GP (Option 5310, 5320, 5330).....	812
Leg GP, Basecutter, Option 5650.....	862
License Plate Harness, CMRV.....	241
License Plate Wiring Harness.....	239
License Plate, CMRV, Wiring Harness.....	241
Light GP, Side Work Standard.....	202
Light, HID, Side Work.....	204
Lights, HID Front Work.....	226
Line GP, Elevator, Swing Table To Top Elevator Frame.....	1030
Line, Fuel Injection Pump-1601-6090HT803.....	104
Line, Fuel Injection Pump-1601-6090HT804.....	32
Line, Turbocharger-6546-6090HT804.....	76
Liner, Cylinder-4609-6090HT803.....	130
Liner, Cylinder-4609-6090HT804.....	58
Liner, Piston Kit-4801-6090HT803.....	134
Liner, Piston Kit-4801-6090HT804.....	62
Liner, Primary Extractor GP.....	986
Lines Basecutter Lift, Wheel.....	444
Lines GP Elevator Extension Frame To Valve (Option 6530).....	1058
Lines GP Elevator Extension Frame To Valve, Option 6530.....	1058
Lines GP, Accessory Valve.....	826
Lines GP, Chopper.....	990
Lines GP, Chopper Basecutter, Standard.....	948
Lines GP, Chopper Curtain Agitator, Option 7170, Track.....	944
Lines GP- Chopper Curtain Agitator, Option 7170, Track.....	944
Lines GP, Control Valve, Feed Roller.....	910
LINES GP, CROP DIVIDER KNOCKDOWN ROLLER (OPTION 5520,5530) {WHEEL}.....	782
LINES GP, CROP DIVIDER LIFT, VALVE TO CYLINDER (OPTION 0501,0511) - WORLD.....	816
LINES GP, CROP DIVIDER LIFT, VALVE TO CYLINDER (OPTION 0501,0511)-LOUISIANA.....	818
Lines GP, Crop Divider Lift, Valve To Cylinder, Louisiana Option 0510, 0511.....	818
Lines GP, Crop Divider Lift, Valve To Cylinder, World Option 0510, 0511.....	816
Lines GP, Crop Divider Tilt, Valve To Cyl (Opt 5210).....	822
Lines GP, Crop Divider Tilt, Valve To Cylinder Option 5210.....	822
Lines GP, Crop Divider Tilt, Valve to Cylinder, Option 5210.....	824
LINES GP, CROP DIVIDER, LEFT (OPTION 5530) {WHEEL}.....	790
Lines GP, Crop Divider, Left Option 5530 Wheel.....	790
Lines GP, Crop Divider, Left, Option 5300, 5310, Track.....	828
Lines GP, Crop Divider, Left, Option 5300, 5310, Wheel.....	830
Lines GP, Crop Divider, Left, Option 5510, 5520, Wheel.....	832
Lines GP, Crop Divider, Right Hand, Option 5300, Track.....	760
Lines GP, Crop Divider, Right, Option 5510, Wheel.....	834
Lines GP, Crop Divider, Right, Wheel.....	798
Lines GP, Crop Divider, W/O Scroll, Left, Wheel.....	804
Lines GP, Dual Crop Divider W/CDKD, Left.....	780
Lines GP, Elevator Drive, Valve To Motor.....	1042
Lines GP, Elevator Drive, Variable.....	1044
Lines GP, Elevator Extension, Frame To Valve (Option 6510).....	1024
Lines GP, Elevator Lift.....	1048
Lines GP, Elevator Swing, Valve to Cylinder.....	1040
Lines GP, Elevator, Extension, Frame To Valve, Option 6510.....	1024
Lines GP, Elevator, Extension, Frame To Valve, Option 6520.....	1026
Lines GP, Elevator, Frame To Valve.....	1022
Lines GP, Elevator, Main Frame to Swing Table.....	1038
Lines GP, Elevator, Main Frame To Swing Table.....	1038
Lines GP, Elevator, Pump To Swing Table.....	1060
Lines GP, Feed Roller, Billet Length Control HP.....	886
Lines GP, Feed Roller, Billet Length Control Standard.....	890
Lines GP, Feed Rollers, Left.....	888
Lines GP, Grease, Primary Extractor Ring.....	978
Lines GP, Ground Drive Standard.....	322
Lines GP, Ground Drive Tank Pump Motor Option 0911 Track.....	308
Lines GP, Ground Drive, Control, Half Track.....	306
Lines GP, Ground Drive, Half Track.....	304
Lines GP, Ground Drive, Tank To Pump To Motor, Option 95BI, Track, (100601-).....	304
Lines GP, Ground Drive-Tank-Pump-Motor (Option 0911) {Track} (100601-).....	308
Lines GP, Ground Drive-Tank-Pump-Motor (Option 95BI) {Track}.....	322
Lines GP, Half Track, Wheel, Park Brake.....	408
Lines GP, Knockdown and Finned Roller, Option 5310, 5320, 5330.....	902
Lines GP, Knockdown Roller, Tilt, Option 5210.....	884
Lines GP, Park Brake.....	414
Lines GP, Park Brake, Half Track, Wheel.....	408
Lines GP, Park Brake, Standard, Wheel.....	406
Lines GP, Park Brake, Two Speed.....	412
Lines GP, Park Brake, Wheel.....	406, 410
Lines GP, Primary Extractor Hood Rotate, Valve to Motor.....	1002
Lines GP, RH, Crop Divider W/O Scroll, Wheel.....	788
Lines GP, RH, Dual Crop Divider, Track.....	784
Lines GP, Right Hand Dual Crop Divider, Side Knife, With Knockdown, Option 5520, 5530, Wheel.....	782
Lines GP, Right Hand Scroll, Side Knife.....	792
Lines GP, Scroll Inner, Pump to Valve, Option 0501, Wheel.....	758
Lines GP, Scroll Left W/CDKD, Track.....	778
LINES GP, SCROLL, OUTER, LEFT (OPTION 5320,5330,5340) {TRACK}.....	772
Lines GP, Scroll, Outer, Left Option 5310, 5320, 5330, 5340.....	772
Lines GP, Scroll, Outer, Left, Attachment.....	802
LINES GP, SCROLL, OUTER, RIGHT (OPTION 5310,5320,5330,5340) {TRACK}.....	766
Lines GP, Scroll, Outer, Right Option 5310, 5320, 5330, 5340.....	766
LINES GP, SCROLL, RIGHT/SIDE KNIFE/CD KCKDN (OPTION 5520,5530) {WHEEL}.....	782
LINES GP, SEC EXT/SEC EXT HOOD ROT (OPTION 6420).....	1050
Lines GP, Secondary Extractor Hood, Standard.....	1054
Lines GP, Secondary Extractor, Valve To Motor, Option 6420.....	1050
LINES GP, SIDE KNIFE RIGHT (OPTION 5520, 5530) {WHEEL}.....	782
Lines GP, Side Knife, Left, Option 5330.....	814
Lines GP, Sill Roller, Option 6010.....	930
Lines GP, Variable Elevator Drive.....	1044
Lines GP, Wheel, Park Brake.....	410
Lines GP-Side Knife-Left, Attachment.....	802
Lines GP-Side Knife-Right (Option 5310, 5320, 5330).....	808

Alphabetical Index - Continued

	Page		Page
Lines GP-Side Knife-Right, Option 5310, 5320, 5330	808	Main Frame Wiring Harness	232, 246
Lines Hydraulic, Ground Drive	474	Main Frame Wiring Harness, CMRV India	234
Lines, 6-Bank to 4-Bank	752	Main Frame, CMRV INDIA, Electrical	234
Lines, ABC B/C Lift Wheel My 10	456	Main Frame, CMRV, Wiring Harness	234
Lines, Air Conditioner Pump	644	Main Frame, Electrical	244
Lines, B / C Lift Less, ABC 06	454	Main Frame, Elevator, Shield, Flaps	1010
Lines, Base Cutter Lift Track	450	Main Frame, Shield, Flaps, Elevator	1010
Lines, Basecutter Lift 3520, Track	448	Main Harness (Track)	258
Lines, Basecutter Lift Cylinder, 3520, Track	448	Main Harness, Track	258
Lines, Basecutter Lift, 3520, Track	440, 442	Mainframe MY12, Harness	246
Lines, Basecutter Lift, ABC, Attachment	438	Manifold Four Bank, Valve GP (Option 5210)	498
Lines, Basecutter Lift, Pump To Valve, Option 3200, Wheel	434	Manifold, Exhaust-2802-6090HT803	116
Lines, Basecutter Lift, Pump To Valve, Option 3210, Wheel	436	Manifold, Exhaust-2814-6090HT804	44
Lines, Cab Tilt	464	Manifold, Intake-1701-6090HT803	106
Lines, Control, Outer Scroll	746	Manifold, Intake-1707-6090HT804	34
Lines, Cooling Fan Motor To Hydraulic Pump	470	MAP Sensor-1701-6090HT803	106
Lines, Crop Divider	838	Master Disconnect Switch	194
Lines, Crop Divider Grease	838	Mat Floor	650
Lines, Elevator HP	1032	MAT Sensor-1701-6090HT803	106
Lines, Elevator Pump, Feed Roller to Crop Divider	490	Mirror, Convex	578
Lines, Flexible Crop Divider Lift, Wheel	462	Mirrors, Cab	642
Lines, Floating Crop Divider Lift	458	Module, Flasher	654
Lines, Fuel Filter, 30 Micron	188	Molex, Connector, Three Contact Lock Type, Cab	294
Lines, Grain Drive Track	324	Monitor Wiring Harness, Cab	622
Lines, Ground Drive Half Track	306	Motor Assembly, Wiper Long	662
Lines, Hydraulic Oil Cooler	466, 468	MOTOR FEED ROLLER B1 (OPTION 5720), B2 (OPTION 1000,1020)	900
Lines, Hydraulic Oil Cooler, Louisiana	468	Motor GP, Ground Drive, Track Hi/Low Option	326
Lines, Hydraulic Oil Cooler, Standard	466	Motor Main Scroll, Mount Assembly, Crop Divider	738
Lines, Inner Scroll, Pump to Valve, Track	756	Motor Secondary Extractor, Option 6400	1086
Lines, Outer Scroll Control	746	Motor Side Knife (Option 5310, 5320, 5330)	810
Lines, Parking Brake, Standard	404	Motor Standard, 25 Compact	786
Lines, Parking Brake, Wheel (121201 -)	416	Motor, Basecutter GP, Option 1000,1020	872
Lines, Primary Extractor, Pump to Motor	992	Motor, Chopper Curtain Agitator, Option 7170, Track	952
Lines, Shredder Topper Boom to Motor	684	Motor, Chopper, Option 1000, 1020	950
Lines, Shredder Topper Collector Boom to Motor	694	Motor, Crop Divider Knockdown Roller, Option 5510, 5520	848
Lines, Shredder Topper with Piston Motor, Boom to Motor	686	Motor, Crop Divider, Inner, Option 5310, 5320, 5330	846
Lines, Steering Wheel	424	Motor, Crop Divider, Outer (Option 5310, 5320, 5330)	850
Lines, Steering Wheel Valves	424	Motor, Crop Divider, Outer, Option 5310, 5320, 5330	850, 918
Lines, Topper Collector, Boom To Motor	692, 694	Motor, Feed Roller B1, Option 5700	898
Lines, Topper Collectors Boom To Motor, Option 5000	692	Motor, Feed Roller B2, Option 1010	762
Lines, Topper Collectors, Valve to Boom	690	Motor, Feed Roller B2, Option 1010, 1030	912
Lines, Topper Lift	706	Motor, Feed Roller, B1 Option 5720, B2 Option 1000, 1020	900
Lines, Topper Lift, Whole, Shredder and Piston Motor	706	Motor, Feed Roller, B2, B3, B4, B5, T1, T2, T3, T4, T5	914
Lines, Topper Pump To Valve To Boom	710	Motor, Ground Drive 800CC (1 of 2)	348
Lines, Topper, Boom To Motor	682, 684, 686	Motor, Ground Drive 800CC, (2of2)	350
Lines, Whole Shredder Topper Collector, Valve to Boom	690	Motor, Ground Drive Track	320
Lines, Whole Topper Boom to Motor	682	Motor, Ground Drive wheel (1 of 2)	354
Lines, Whole Topper Collector Boom to Motor	692	Motor, Ground Drive Wheel (2 of 2)	356
Lines, Windshield Washer, Bulkhead to Nozzles	660	Motor, Ground Drive, Left Hi/Low Option	328
Load Center Cab Harness	294	Motor, Ground Drive, Left Hi/Low Option (Cont)	330
Load Center Cab Harness and Connectors (1 of 2)	296	Motor, Ground Drive, Left, Hi/Low Option	328
Load Center Cab Harness and Connectors (2 of 2)	298	Motor, Ground Drive, Track	302, 318
Load Center Harness and Connections	292	Motor, Ground Drive, Wheel	352
Load Center, Cab Elec GP	294	MOTOR, GROUND DRIVE(TRACK)	320
Load Center, Harness	292	Motor, Knockdown Roller, Fixed	836, 904
Louisiana Crop Divider, Track, MESA	726	Motor, Oil Cooler	484
Louisiana High Mount Track Frame	370	Motor, Primary Extractor	1000
Louisiana, Crop Divider	730	Motor, Primary Extractor Hood Rotate	1004
Louisiana, Crop Divider Floating Shoe	714	Motor, Secondary Extractor, Option 6420	1052
		Motor, Shredder Topper Piston	688
M		Motor, Side Knife, Option 5310, 5320, 5330	810
Magnet, Lines GP, Park Brake	414	Motor, Starting-3002-6090HT803	120
Main Arm, Idler Arm, Wiper Assembly	662	Motor, Starting-3002-6090HT804	48
Main Bearing Cap-4609-6090HT803	130	MOTOR, TOPPER COLLECTOR (OPTION 5000, 5010,5020)	1046
Main Bearing Cap-4609-6090HT804	58	Motor, Topper Collector Option 5000, 5010, 5020	1046
Main Bearings-4701-6090HT803	132	Motor, Topper Collector, Whole, Shredder and Piston Motor	704
Main Bearings-4701-6090HT804	60	Motor-Basecutter, Option 1000,1020	872
Main Extension Harness, Track	258	Mount Bulk Head Wire Harness, Cab	294
Main Frame Elevator Extension Harness, MESA	252	Mount GP, Basecutter	856
Main Frame Extension Harness (Track)	250	Mount GP, Cooling Fan (Option 1020,1030)	568
Main Frame Extension Harness, CE, CMRV, MESA	254	Mount GP, Outer Scroll, Left (Option 5320,5330,5340)	774
Main Frame Extension Harness, Track	250	Mount GP, Outer Scroll, Left, Attachment	802
Main Frame Extension Wiring Harness, Wheel	248	Mount GP, Outer Scroll, Left, Option 5320, 5330, 5340	774
Main Frame Extension, Electrical Harness	250	Mount GP, Outer Scroll, Right (Opt 5310, 5320,5330,5340)	768
Main Frame Extension, Elevator, Electrical GP	252	Mount GP, Outer Scroll, Right, Attachment	796
Main Frame Harness and Hardware	244	Mount GP, Outer Scroll, Right, Option 5310, 5320, 5330, 5340	768
Main Frame Mountings (Wheel) (Half Track)	558	Mount GP, Plastic Fuel Tank	180
Main Frame Mountings, Standard, Track	554	Mount GP, Primary Extractor Motor	984
Main Frame Mountings, Track	556	Mount GP, Scroll Outer, Left (Option 5320,5330,5340)	774
Main Frame Mountings, Wheel	560	Mount GP, Scroll, Outer, Left (Option 5320,5340)	800
Main Frame Mountings, Wheel Half Track	558	Mount GP, Scroll, Outer, Left, Option 5320, 5340	800
		Mount GP, Vine Knife, Crop Divider, Option 9030	852

Alphabetical Index - Continued

Page	Page		
Mount, Hydraulic Steering	422	Option 1020 Lines GP, Feed Roll, RH With Option 7250	890
Mount, Roller Bearing	744	OPTION 1020 MOTOR, FEED ROLLER B2	900
Mount, Scroll Outer Motor, RH	742	Option 1020, 1000 Motor, Chopper	950
Mount, Steering Controller	418	Option 1020,1000 Motor-Basecutter	872
Mount, Steering Controller (Option 0582)	418	OPTION 1020,1000 PUMP , CHOPPER/BASE- CUTTER (100601-)	966
Mount, Steering Hydraulic (Option 0572)	422	Option 1020,1000 Pump, Chopper, Basecutter	972
Mounting GP, Receiver, GS	614	Option 1020,1030 Mount GP, Cooling Fan	568
Mounting Parts, Light GP, CMRV, India	580	Option 1030 Lines GP, Feed Roll, RH, with Option 7250	886
Mounting Plug, Air Compressor-7899-6090HT803	156	Option 1030, 1010 Motor, Feed Roller B2	912
Mounting Plug, Air Compressor-7899-6090HT804	82	Option 1030,1020 Mount GP, Cooling Fan	568
Muffler	186	Option 3200 Lines, Basecutter Lift, Pump To Valve, Wheel	434
		Option 3210 Lines, Basecutter Lift, Pump To Valve, Wheel	436
		OPTION 5000 MOTOR, TOPPER	700
		OPTION 5000,5010,5020, MOTOR, TOPPER COLLECTOR	704, 1046
		OPTION 5010 MOTOR, TOPPER	702
		Option 5010, 5020 Lines, Topper Collector, Boom To Motor	694
		OPTION 5010,5000,5020, MOTOR, TOPPER COLLECTOR	1046
		OPTION 5020,5000,5010, MOTOR, TOPPER COLLECTOR	1046
		OPTION 5200 ROLLER GP, KNOCKDOWN	876
		Option 5210 Cylinder, Crop Divider Tilt	894
		Option 5210 Lines GP, Crop Divider Tilt, Valve to Cylinder	824
		Option 5210 Lines GP, Crop Divider Tilt, Valve, Cyl	822
		Option 5210 Lines GP, Knockdown Roller, Tilt	884
		OPTION 5300 LINES GP, CROP DIVIDER, RIGHT {TRACK}	760
		Option 5300, 5310 Lines GP, Crop Divider, Left Wheel	828
		Option 5300, 5310 Lines GP, Crop Divider, Left, Wheel	830
		Option 5310 Lines GP, Knockdown And Finned Roller	902
		Option 5310, 5300 Lines GP, Crop Divider, Left Track	828
		Option 5310, 5300 Lines GP, Crop Divider, Left, Wheel	830
		Option 5310, 5320, 5330 Motor, Crop Divider, Inner	846
		Option 5310, 5320, 5330 Motor, Side Knife	810
		Option 5310, 5320, 5330 Side Knife GP, Left	812
		Option 5310, 5320, 5330 Side Knife GP, Right	806
		Option 5310, 5320, 5330 Valve, Scroll, Outer	842, 908
		Option 5310,5320,5330 Lines Gp-Side Knife-Right	808
		Option 5310,5320,5330 Motor, Crop Divider, Outer	918
		OPTION 5310,5320,5330,5340 LINES GP, SCROLL, OUTER, RIGHT {TRACK}	766
		Option 5310,5320,5330,5340 Mount GP, Outer Scroll, Right	768
		Option 5320 Lines GP, Knockdown And Finned Roller	902
		Option 5320, 5310, 5330 Motor, Crop Divider, Inner	846
		Option 5320, 5310, 5330 Motor, Side Knife	810
		Option 5320, 5310, 5330 Side Knife GP, Left	812
		Option 5320, 5310, 5330 Side Knife GP, Right	806
		Option 5320, 5310, 5330 Valve, Scroll, Outer	842, 908
		Option 5320,5310,5330 Lines Gp-Side Knife-Right	808
		OPTION 5320,5310,5330,5340 LINES GP, SCROLL, OUTER, RIGHT {TRACK}	766
		Option 5320,5310,5330,5340 Mount GP, Outer Scroll, Right	768
		Option 5320,5330,5310 Motor, Crop Divider, Outer	918
		OPTION 5320,5330,5340 LINES GP, SCROLL, OUTER, LEFT {TRACK}	772
		Option 5320,5330,5340 Mount GP, Outer Scroll Left	774
		Option 5320,5340 Mount GP, Scroll Outer, Left	800
		Option 5330 Lines GP, Knockdown And Finned Roller	902
		Option 5330 Lines GP, Side Knife, Left	814
		Option 5330, 5310, 5320 Motor, Crop Divider, Inner	846
		Option 5330, 5310, 5320 Motor, Side Knife	810
		Option 5330, 5310, 5320 Valve, Scroll, Outer	842, 908
		Option 5330, 5310, 5320, Side Knife GP, Left	812
		Option 5330, 5310, 5320, Side Knife GP, Right	806
		Option 5330,5310,5320 Lines Gp-Side Knife-Right	808
		Option 5330,5310,5320 Motor, Crop Divider, Outer	918
		OPTION 5330,5310,5320,5340 LINES GP, SCROLL, OUTER, RIGHT {TRACK}	766
		Option 5330,5310,5320,5340 Mount GP, Outer Scroll, Right	768
		Option 5330,5320,5340 Mount GP, Outer Scroll Left	774
		OPTION 5330,5340,5320 LINES GP, SCROLL, OUTER LEFT {TRACK}	772
		OPTION 5340,5310,5320,5330 LINES GP, SCROLL, OUTER, RIGHT {TRACK}	766
		Option 5340,5310,5320,5330 Mount GP, Outer Scroll, Right	768
		Option 5340,5320 Mount GP, Scroll Outer, Left	800
		OPTION 5340,5320,5330 LINES GP, SCROLL, OUTER, LEFT {TRACK}	772
		Option 5340,5320,5330 Mount GP, Outer Scroll Left	774
		Option 5510 Lines GP, Crop Divider, Right, Wheel	834
		Option 5510, 5520 Lines GP, Crop Divider, Left Wheel	832
		Option 5510, 5520 Motor, Crop Divider Knockdown Roller	848
		Option 5510,5520,5530 Crop Divider GP, Knockdown	794
		Option 5520, 510 Lines GP, Crop Divider, Left Wheel	832